



SPECIFICATION

宏致電子股份有限公司

桃園縣中壢市東園路13號

No.13, Dongyuan Rd., Jhongli City,

Taoyuan County 320, Taiwan (R.O.C.)

TEL: +886-3-463-2808

FAX: +886-3-463-1800

SPEC. NO.: PS-51322-XXXXX-XXX

REVISION: 0

PRODUCT NAME: 1.25mm WIRE TO BOARD WAFER LPF-2 SMT R/A TYPE

PRODUCT NO: 51322 50280 SERIES.

PREPARED: ZHOUQUAN DATE: 2016.3.30	CHECKED: BRAVE DATE: 2016.3.30	APPROVED: FRANK DATE: 2016.3.30
---	---	--



Aces P/N: **51322 series**

TITLE: **1.25mm WIRE TO BOARD WAFER LPF-2 SMT R/A**

RELEASE DATE: 2016.3.30

REVISION: 0

ECN No: ECN-1603345

PAGE: **2** OF **15.**

1	REVISION HISTORY	3
•2	SCOPE	4
3	APPLICABLE DOCUMENTS.....	4
4	REQUIREMENTS	4
5	PERFORMANCE	5
6	INFRARED REFLOW CONDITION	8
7	PRODUCT QUALIFICATION AND TEST SEQUENCE.....	9
8	ANATOMY OF CRIMPING TERMINAL.....	10
9	APPLICABLE WIRES: UL10584 ETFE WIRE.....	11
10	CRIMPING CONDITION	11
11	CRIMPING HEIGHT MEASUREMENT	12
12	PULL FORCE OF CRIMPING SECTION MEASUREMENT.....	13
13	STANDARD INSULATION CRIMPING	13
14	CONDUCTORS CRIMPING CONDITION.....	14
15	CRIMPING REQUIREMENT	15



Aces P/N: **51322 series**

TITLE: **1.25mm WIRE TO BOARD WAFER LPF-2 SMT R/A**

RELEASE DATE: 2016.3.30

REVISION: 0

ECN No: ECN-1603345

PAGE: **3** OF **15.**

1 REVISION HISTORY

Rev.	ECN #	Revision Description	Prepared	Date
0	ECN-1603345	NEW SPEC PROPOSAL	ZHOUQUAN	2016.3.30



Aces P/N: **51322 series**

TITLE: **1.25mm WIRE TO BOARD WAFER LPF-2 SMT R/A**

RELEASE DATE: 2016.3.30

REVISION: 0

ECN No: ECN-1603345

PAGE: **4** OF **15.**

2 SCOPE

This specification covers performance, tests and quality requirements for 1.25mm pitch WTB connector. This Product Spec. Refer to...Aces- P/N : **51322 Series.**

3 APPLICABLE DOCUMENTS

EIA-364: ELECTRONICS INDUSTRIES ASSOCIATION

4 REQUIREMENTS

4.1 Design and Construction

- 4.1.1 Product shall be of design, construction and physical dimensions specified on applicable product drawing.
- 4.1.2 All materials conform to R.o.H.S. and the standard depends on TQ-WI-140101.

4.2 Materials and Finish

- 4.2.1 Contact: High performance copper alloy.
Finish: (a) Contact Area: [Refer to the drawing.](#)
(b) Under plate: [Refer to the drawing.](#)
(c) Solder area: [Refer to the drawing.](#)
- 4.2.2 Housing: Thermoplastic or Thermoplastic High Temp., UL94V-0
- 4.2.3 Fitting Nail: [Copper Alloy](#),
Finish: [Refer to the drawing.](#)

4.3 Ratings

- 4.3.1 [Working voltage less than 36 volts \(per pin\)](#)
- 4.3.2 Voltage: [200 Volts AC \(per pin\)](#)
- 4.3.3 Current: [AWG#26: 2.3 Amperes \(per pin UL10584\)](#)
[AWG#28: 1.8 Amperes \(per pin UL10584\)](#)
[AWG#30: 1.0 Amperes \(per pin UL10584\)](#)
[AWG#32: 0.8 Amperes \(per pin UL10584\)](#)
[AWG#30: 1.0 Amperes \(per pin UL3302\)](#)
- 4.3.4 Operating Temperature : [-40°C to +85°C](#)

5 Performance

5.1. Test Requirements and Procedures Summary

Item	Requirement	Standard
Examination of Product	Product shall meet requirements of applicable product drawing and specification.	Visual, dimensional and functional per applicable quality inspection plan.

ELECTRICAL

Item	Requirement	Standard
Low Level Contact Resistance	55 m Ω Max.(initial)per contact ΔR 20 m Ω Max.	Mate connectors, measure by dry circuit, 20mV Max., 100mA Max. (EIA-364-23)
Insulation Resistance	100 M Ω Min.	Unmated connectors, apply 500 V DC between adjacent terminals. (EIA-364-21)
Dielectric Withstanding Voltage	No discharge, flashover or breakdown. Current leakage: 1 mA max.	500V AC Min. at sea level for 1 minute. Test between adjacent contacts of unmated connectors. (EIA-364-20)
Temperature Rise	30°C Max. Change allowed	Mate connector: measure the temperature rise at rated current until temperature stable. The ambient condition is still air at 25°C (EIA-364-70,METHOD1,CONDITION1)

MECHANICAL

Item	Requirement	Standard
Durability	30 cycles.	The sample should be mounted in the tester and fully mated and unmated the number of cycles specified at the rate of 25.4 ± 3mm/min.
Mating / Unmating Forces	Mating Force:0.6Kgf/pin MAX Unmating Force:0.05Kgf/pin MIN	Operation Speed : 25.4 ± 3 mm/minute. Measure the force required to mate/unmated connector. (EIA-364-13)
Contact Retention Force (Board Side)	0.30 Kgf Min.	Operation Speed : 25.4 ± 3 mm/minute. Measure the contact retention force with tester.
Shell /Housing Retention Force(Board Side)	0.40 Kgf MIN.	Apply axial pull out force at the speed rate of 25.4 ± 3 mm/minute. On the fitting nail assembled in the housing.



Aces P/N: **51322 series**

TITLE: **1.25mm WIRE TO BOARD WAFER LPF-2 SMT R/A**

RELEASE DATE: 2016.3.30

REVISION: 0

ECN No: ECN-1603345

PAGE: **6** OF **15.**

• Crimping Terminal / Housing Retention Force (Cable Side)	0.5 Kgf MIN.	Apply axial pull out force at the speed rate of 25.4 ± 3 mm/minute. On the terminal assembled in the housing.
Crimping Pull Out Force	AWG# 26: 9.8N Min. AWG# 28: 9.8N Min. AWG# 30: 4.9N Min. AWG# 32: 3.0N Min.	Operation Speed : 25.4 ± 3 mm/minute. Fix the crimped terminal; apply axial pull out force on the wire.
Vibration	1 us Max.	The electrical load condition shall be 100 mA maximum for all contacts. Subject to a simple harmonic motion having amplitude of 0.76mm (1.52mm maximum total excursion) in frequency between the limits of 10 and 55 Hz. The entire frequency range, from 10 to 55 Hz and return to 10 Hz, shall be traversed in approximately 1 minute. This motion shall be applied for 2 hours in each of three mutually perpendicular directions. (EIA-364-28 Condition I)
Shock (Mechanical)	1 us Max.	Subject mated connectors to 50 G's (peak value) half-sine shock pulses of 11 milliseconds duration. Three shocks in each direction shall be applied along the three mutually perpendicular axes of the test specimen (18 shocks). The electrical load condition shall be 100mA maximum for all contacts. (EIA-364-27, test condition A)

ENVIRONMENTAL

Item	Requirement	Standard
Resistance to Reflow Soldering Heat (Board Side)	See Product Qualification and Test Sequence Group 10 (Lead Free)	Pre Heat : 150°C~180°C, 60~120sec. Heat : 230°C Min., 40sec Min. Peak Temp. : 260°C Max, 10sec Max.
Thermal Shock	See Product Qualification and Test Sequence Group 4	Mate module and subject to follow condition for 5 cycles. 1 cycles: -40 +0/-3 °C, 30 minutes +85 +3/-0 °C, 30 minutes (EIA-364-32, test condition I)
Humidity	See Product Qualification and Test Sequence Group 4	Mated Connector 40°C, 90~95% RH, 96 hours. (EIA-364-31,Condition A, Method II)



Aces P/N: **51322 series**

TITLE: **1.25mm WIRE TO BOARD WAFER LPF-2 SMT R/A**

RELEASE DATE: 2016.3.30

REVISION: 0

ECN No: ECN-1603345

PAGE: **7** OF **15.**

• Temperature Life	See Product Qualification and Test Sequence Group 5	Subject mated connectors to temperature life at 85°C for 96 hours . (EIA-364-17, Test condition A)
Salt Spray (Only For Gold Plating)	See Product Qualification and Test Sequence Group 6	Subject mated/unmated connectors to 5% salt-solution concentration, 35°C (I) Gold plating < 3u" for 8 hours. (II) 3u" ≤ Gold plating < 5u" for 48 hours (III) Gold plating ≥ 5u" for 96 hours. (EIA-364-26)
Solder ability (Board Side)	Tin plating: Solder able area shall have minimum of 95% solder coverage. Gold plating: Solder able area shall have minimum of 75% solder coverage	And then into solder bath, Temperature at 245 ±5°C , for 4-5 sec . (EIA-364-52)
Hand Soldering Temperature Resistance (Board Side)	Appearance: No damage	T ≥ 350°C, 3sec at least.

Note. Flowing Mixed Gas shall be conducted by customer request.

6 INFRARED REFLOW CONDITION

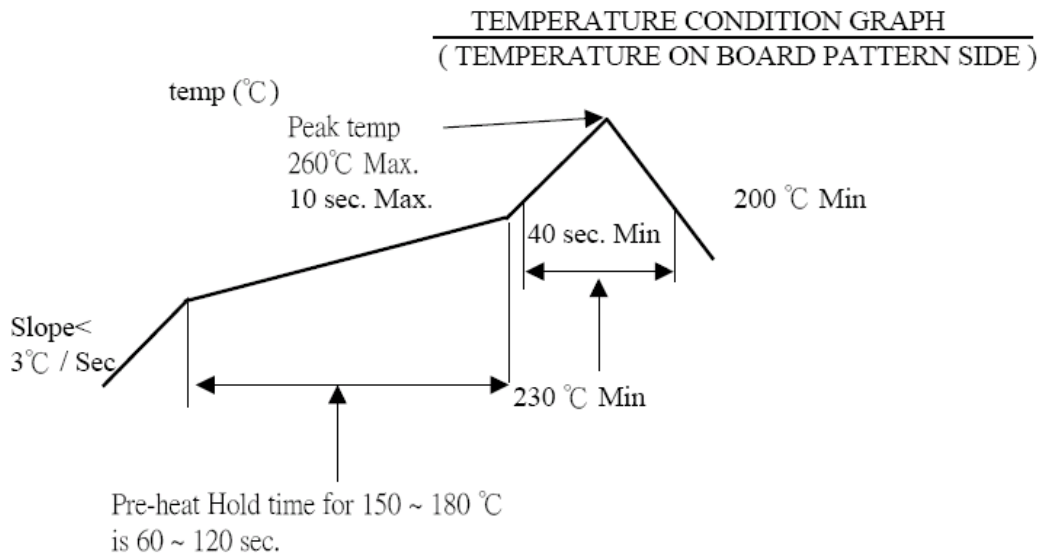



Aces P/N: **51322 series**

TITLE: **1.25mm WIRE TO BOARD WAFER LPF-2 SMT R/A**

RELEASE DATE: 2016.3.30

REVISION: 0

ECN No: ECN-1603345

PAGE: **9** OF **15.**

7 PRODUCT QUALIFICATION AND TEST SEQUENCE

Test or Examination	Test Group										
	1	2	3	4	5	6	7	8	9	10	11
	Test Sequence										
Examination of Product				1、7	1、6	1、4				1	1
Low Level Contact Resistance		1、5	1、4	2、10	2、9	2、5				3	
Insulation Resistance				3、9	3、8						
Dielectric Withstanding Voltage				4、8	4、7						
Temperature Rise	1										
Mating / Unmating Force		2、4									
Durability		3									
Contact Retention Force (Board Side)									3		
Vibration			2								
Shock (Mechanical)			3								
Thermal Shock				5							
Humidity				6							
Temperature Life					5						
Salt Spray(Only For Gold Plating)						3					
Solder ability(Board Side)							1				
Crimping Pull Out Force								1			
Crimping Terminal / Housing Retention Force (Cable Side)									1		
Fitting Nail /Housing Retention Force(Board Side)									2		
Resistance to Soldering Heat (Board Side)										2	
Hand Soldering Temperature Resistance (Board Side)											2
Sample Size	2	4	4	4	4	4	2	4	4	4	4

8 ANATOMY OF CRIMPING TERMINAL

Insulation Crimping Portion

Conductor Crimping Portion

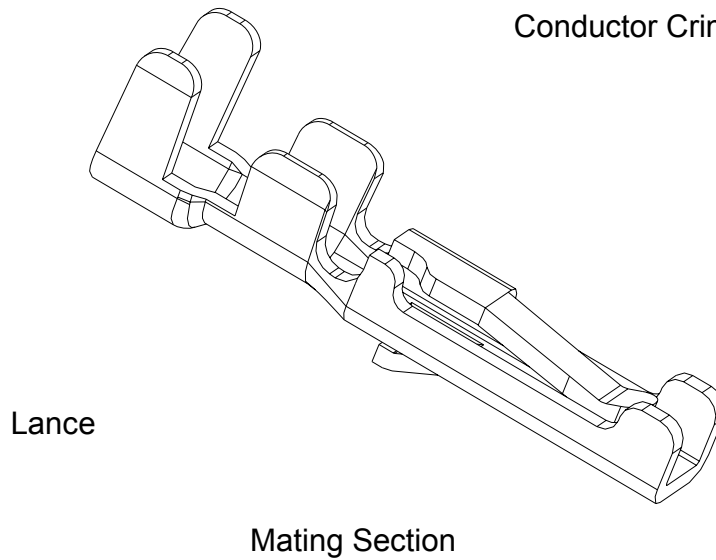

Lance

Mating Section

9 APPLICABLE WIRES: UL10584 AND UL3302 ETFE WIRE

- AWG Size: AWG#26 Insulation OD: Φ 0.90mm (UL10584)
- AWG#28 Insulation OD: Φ 0.80mm (UL10584)
- AWG#30 Insulation OD: Φ 0.70mm (UL10584)
- AWG#32 Insulation OD: Φ 0.40mm (UL10584)
- AWG#30 Insulation OD: Φ 0.60mm (UL3302)

10 CRIMPING CONDITION

鉚線條件表 CRIMPING CONDITION

Part Number	Wire Specification			Crimp Height (mm)		Crimp Width (mm)	
	UL Style	AWG Size	Insulation OD(mm)	Conductor A	Insulation B	Conductor W1	Insulation W2
88232-T	UL10584	26	0.9	0.55~0.65	1.10~1.25	0.95Max.	1.0Max.
88232-T		28	0.8	0.56~0.63	1.20~1.27	0.95Max.	1.0 Max.
88232-T		30	0.7	0.52~0.59	1.03~1.12	0.95Max.	1.0 Max.
88232-T		32	0.4	0.47~0.54	0.96~1.03	0.95Max.	1.0 Max.
88232-T	UL3302	30	0.6	0.57~0.63	1.00~1.07	0.95Max.	1.0 Max.

W2

W

Strip length

Note:

- 1、W1為芯線導體鉚壓後之寬度(Conductor Crimping Width)：W1值如上表
- 2、W2為電線外被部分鉚壓後之寬度(Insulation Crimping Width)：W2值如上表
- 3、A為芯線導體鉚壓後之高度(Conductor Crimping height)：A值如上表(參考值)
- 4、B為電線外被鉚壓後之高度(Insulation Crimping height)：B值如上表(參考值)
- 5、電線剝皮長度(Strip length)：1.4~1.9mm(參考值)

11 CRIMPING HEIGHT MEASUREMENT

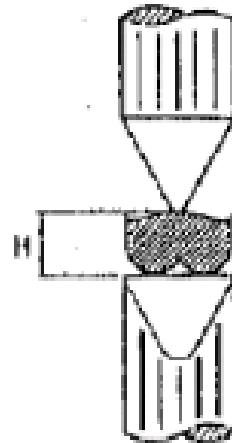
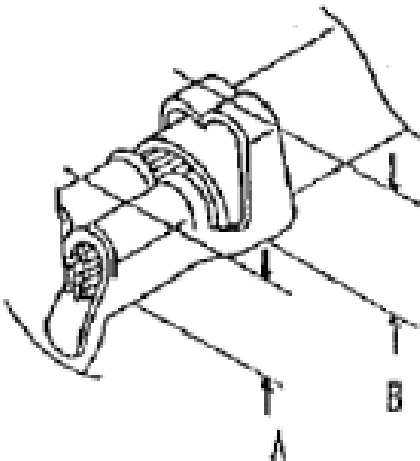
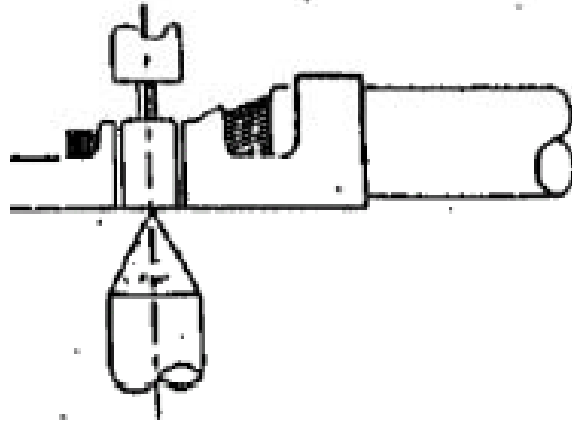
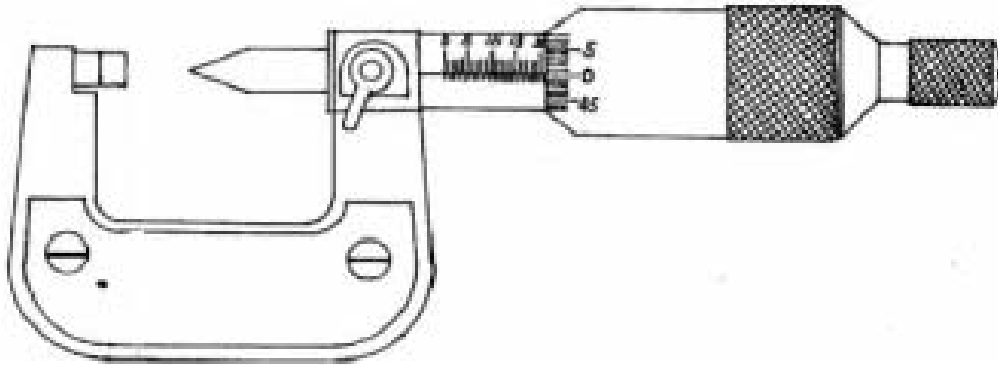

12 PULL FORCE OF CRIMPING SECTION MEASUREMENT



Before test samples, please measure crimp height and do not crimp insulation.



Pull Force of Crimp Section Measurement

13 STANDARD INSULATION CRIMPING

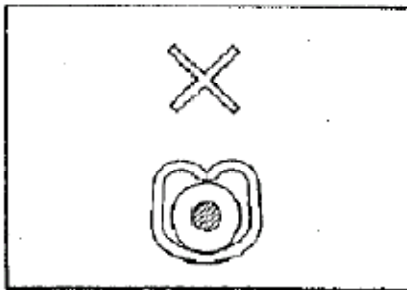

Not enough crimp

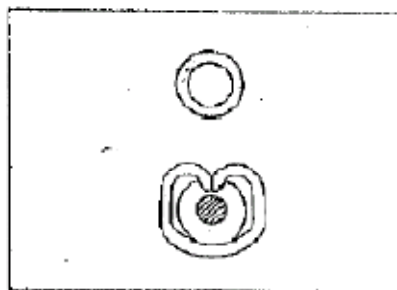

Good

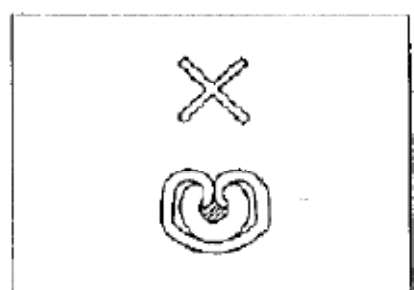

Crimp too much

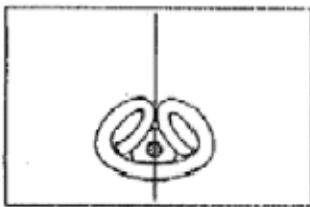

Good

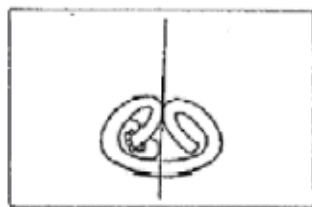

NG

Insulation Crimp Condition

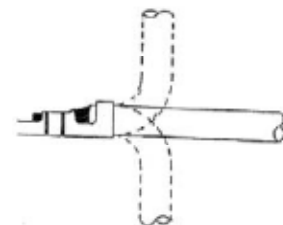

As following figure shown. It is no problem if wire bent up down 90 degrees 1 cycle and insulation position still in ideal position.

14 CONDUCTORS CRIMPING CONDITION

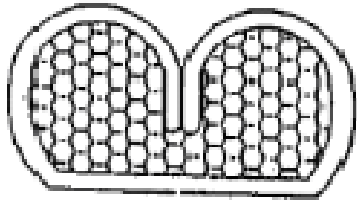

Good

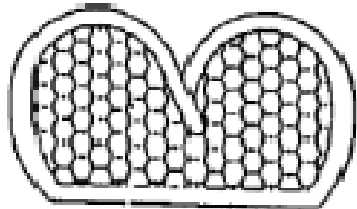

NG

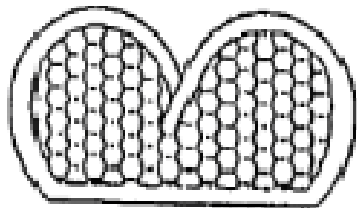

NG

Lower conduct
retension force

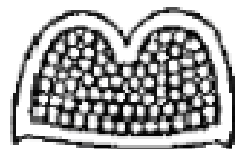

Good

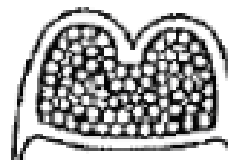

NG

Large burr

15 CRIMPING REQUIREMENT

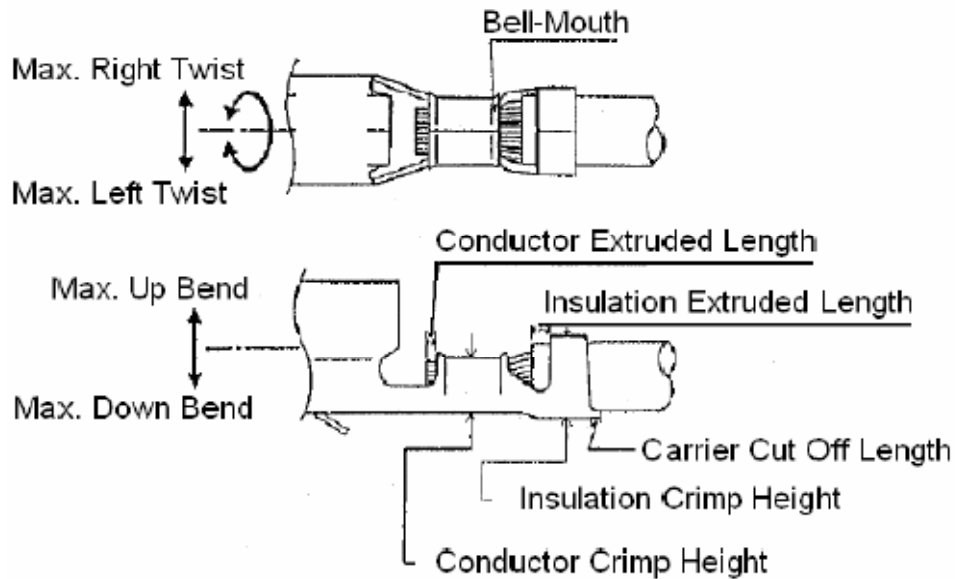

Item	Range(Ref.)
Max. Up Bend	6°
Max. Down Bend	6°
Max. Left Twist	5°
Max. Right Twist	5°
Bell-Mouth Length	0~0.3mm
Carrier Cut Off Length	0~0.2mm
Conductor Extruded Length	0.1~0.3mm